

IRB 1010

Enhanced productivity in extraordinary narrow space



A small robot with a big performance designed to meet the trend towards the manufacture of miniaturized electronics and wearable devices. With the highest payload of 1.5kg, class-leading precision 0.01mm, and 30% smaller size, the IRB 1010 allows for the highest productivity and high-quality manufacturing.

Consumer demand for smart and wearable devices such as sensors, watches, earphones, glasses, sport, and health trackers, is growing at a rapid-fire pace around the world. Products are smaller and lighter than before. Manufacturers need a smaller robot with higher performance. ABB's smallest ever industrial robot, the IRB 1010 is designed to meet this demand by enabling fast and accurate handling of complex manufacturing processes involving small and delicate components.

The IRB 1010 is also an ideal solution for educational applications. Its compact design makes it suitable for installation on classroom desktops, while its ease-of-use enables both teachers and students to quickly master the skills needed for programming and operation.

Key benefits

- **ABB's smallest industrial robot:** With a 30% smaller* size, IRB 1010 enables it to be installed in even the tightest production spaces, including as part of special purpose machines, accommodating high-density factory layouts and enabling more production by fully utilizing available space.
- **Highest payload for enhanced productivity:** With its class-beating payload of 1.5kg, the IRB 1010 can handle more objects than other lighter payload robots in its class in less time, increasing throughput and productivity.
- **6 brake systems for no production delays:** The inclusion of 6 brake systems enables the robot arm to remain in-situ even when the robot is shut down or paused. With no time needed for the arm to recover its position, the IRB 1010 can resume production faster, delivering higher productivity than other robots in its class.

- **Class-leading precision:** Unmatched position and path repeatability of 0.01mm enable accurate and high-quality manufacturing.
- **Powered by OmniCore:** E10 ultra-slim controller offers best-in-class motion control, 20 percent energy savings (compared with ABB's IRC5 controller) and futureproofing through built-in digital connectivity and 1000+ additional functions to meet changing requirements. The best repeatability is achieved by best-in-class motion control.
- **Added vacuum suction for improved handling:** The larger diameter (Φ4mmx 2 pieces) of the upper arm air hose provides additional power for vacuum suction, making it possible to handle more objects simultaneously and increasing the number of items that can be handled per hour, enabling the IRB 1010 to offer higher productivity than other robots in its class.
- **Simple programming with Robot Control Mate:** Enables users to move, teach and calibrate IRB 1010 from their computers or smart devices such as tablets in real-time, making it easier than ever to control a robot's movements.

* Compared with IRB 120.

Applications:

Material handling, picking and placing, film peeling, bending, and assembly

Specification

Robot version	Reach (m)	Payload (kg)	Armload (kg)
IRB 1010-1.5/0.37	0.37	1.5	0.2
Number of axes	6		
Protection	IP40		
Mounting	Floor, Ceiling		
Controller	OmniCore E10		
Integrated signal and power supply	12 Signals on wrist ¹		
Integrated air supply	2 air on wrist (Max. 6 Bar) ¹		

¹ There are some reachable space limitation when the payload/pose is tough.

Performance (according to ISO 9283)

	IRB 1010-1.5/0.37
Pose repeatability, RP	0.01 mm
Pose stabilization time, PSt (s) within 0.1 mm of the position	0.04
Path repeatability, RT	0.01 mm

Performance

	IRB 1010-1.5/0.37
1 kg picking cycle	
25 x 300 x 25 mm	0.54

Physical

Robot base (mm)	135x250
Robot weight (kg)	13.5

Movement

Axis movement	Working range	Axis max speed (°/s)
Axis 1	+170 to -170	320
Axis 2	+125 to -75	320
Axis 3	+50 to -180	375
Axis 4	+170 to -170	500
Axis 5	+125 to -125	470
Axis 6	+360 to -360	500

Working range, IRB 1010-1.5/0.37

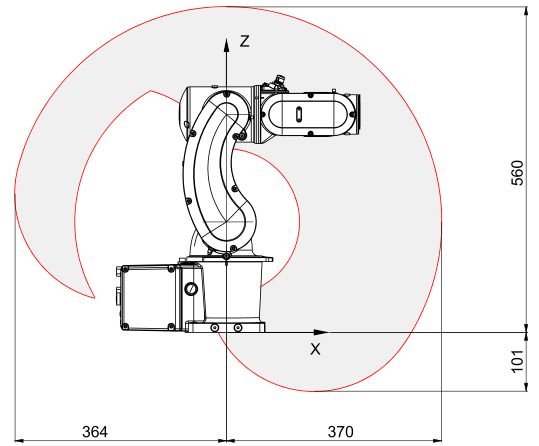

Dimension, IRB 1010-1.5/0.37

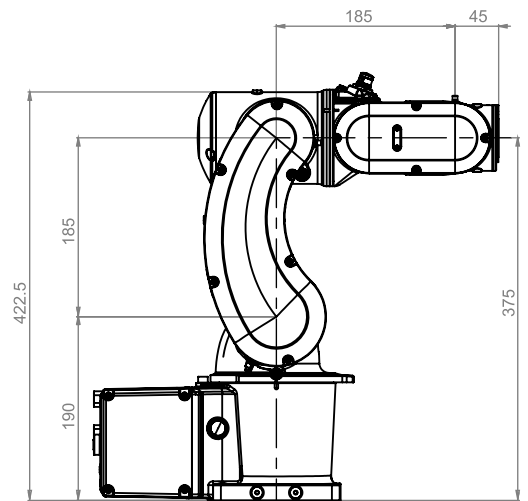

OmniCore E10 ultra slim controller

