

IRB 1200-7/0.7

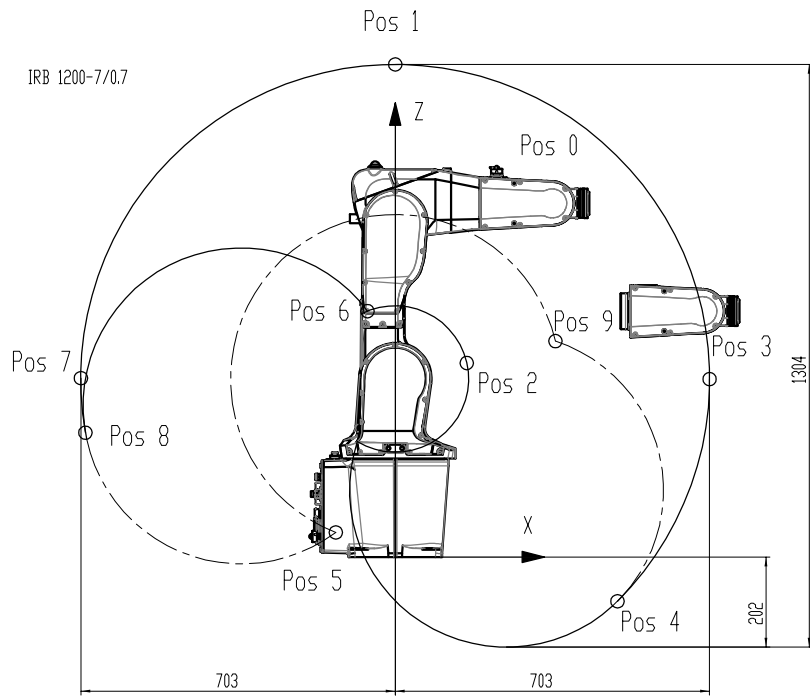

IRB 1200-5/0.9

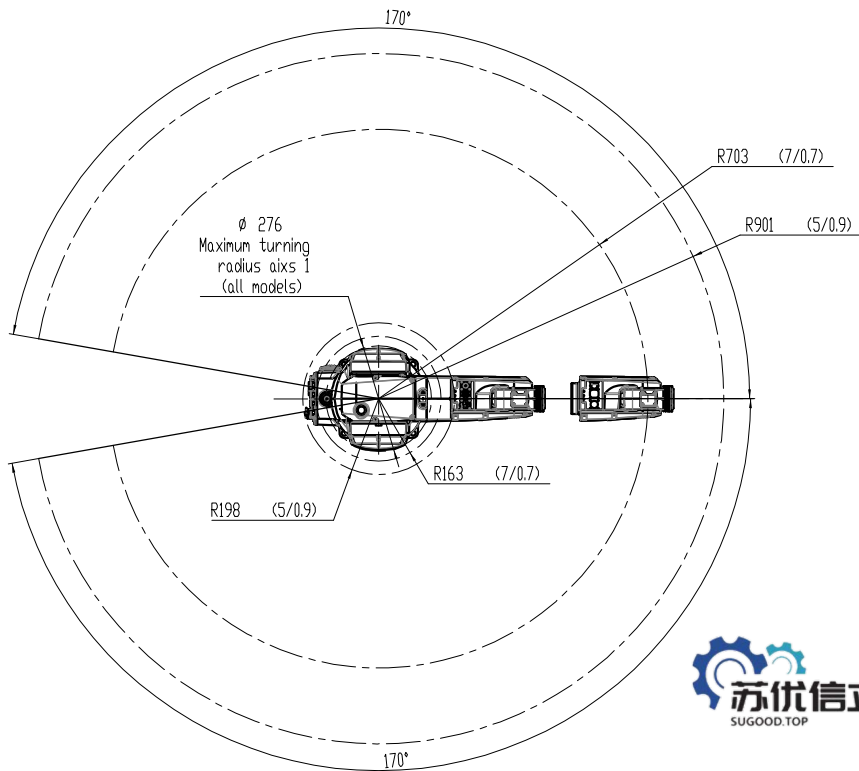
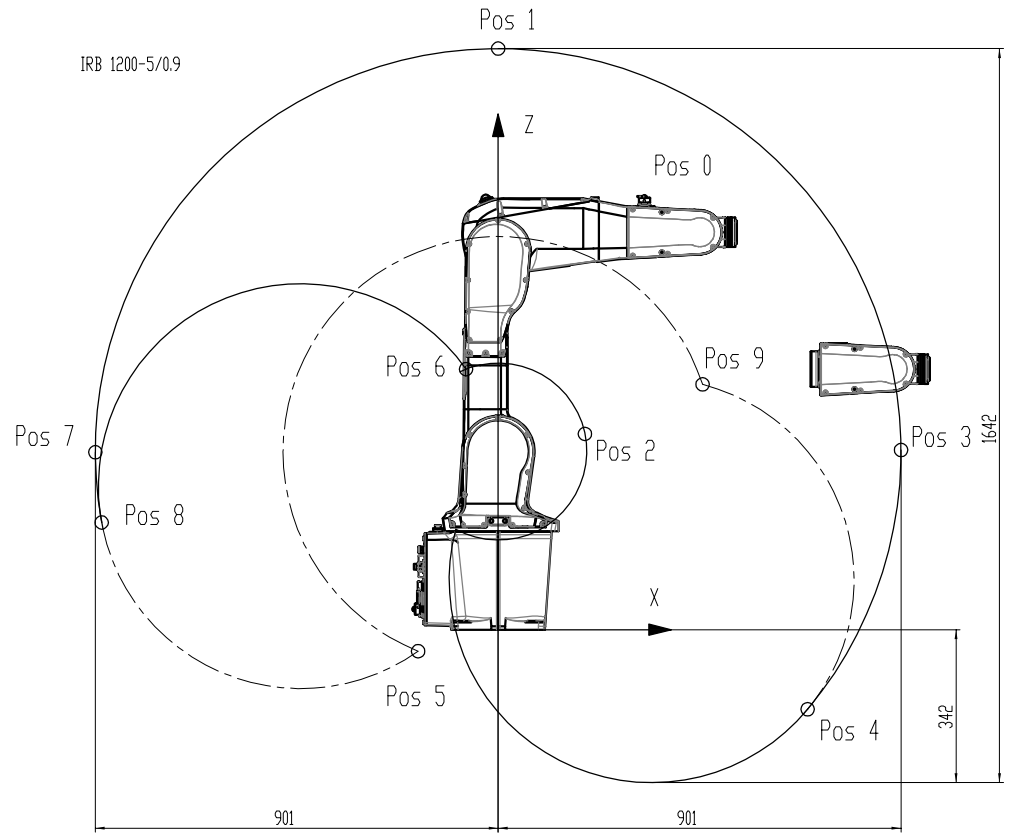

IRB 1200-7/0.7

Pos	Position at wrist center (mm)		Angle (degrees)	
	X	Z	Axis 2	Axis 3
0	351	791	0	0
1	0	1102	0	-83
2	160	434	0	+70
3	703	398	+90	-83
4	497	-99	+135	-83
5	-133	55	-100	-200
6	-62	550	-100	+70
7	-703	400	-90	-83
8	-693	278	-100	-83
9	358	488	135	-200

IRB 1200-5/0.9

Pos	Position at wrist center (mm)		Angle (degrees)	
	X	Z	Axis 2	Axis 3
0	451	889	0	0
1	0	1300	0	-85
2	194	438	0	+70
3	901	402	+90	-85
4	692	-178	+130	-85
5	-179	-48	-100	-200
6	-72	583	-100	+70
7	-901	397	-90	-85
8	-887	240	-100	-85
9	458	549	130	-200

IRB 1200-7/0.7

Working range		
Ax.1	+170 °	-170 °
Ax.2	+135 °	-100 °
Ax.3	+70 °	-200 °
Ax.4	+270 °	-270 °
Ax.5	+130 °	-130 °
Ax.6	+360 °	-360 °

IRB 1200-5/0.9

Working range		
Ax.1	+170 °	-170 °
Ax.2	+130 °	-100 °
Ax.3	+70 °	-200 °
Ax.4	+270 °	-270 °
Ax.5	+130 °	-130 °
Ax.6	+360 °	-360 °



武永康
13913235524
(微信同号)

Material/Type		Dimension	
Prepared J Zhou, 140210	Responsible Department DMRC CN/RM	Description	SWD Drawing
Approved	Take over department	Working area IRB 1200	Sheet 1
Status Origin Reserved	EQ number 500000059106	Document no.	Work sh 1
Latest Revision		ABB 3HAC046307-005	