

1 Description

1.3.3 Mounting the manipulator

Continued

Note regarding M_{xy} and F_{xy}

The bending torque (M_{xy}) can occur in any direction in the XY-plane of the base coordinate system. The same applies to the transverse force (F_{xy}).

Fastening holes robot base

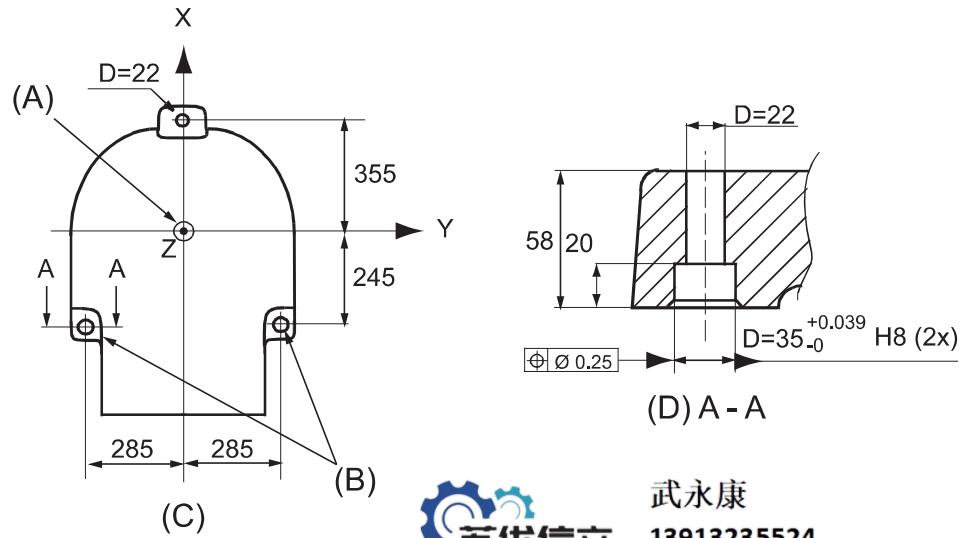

xx1100000594



武永康
13913235524
(微信同号)

Pos	Description
A	Z= center line
B	The same dimensions
C	View from bottom of the base
D	Section

Continues on next page

Mounting surface and bushings

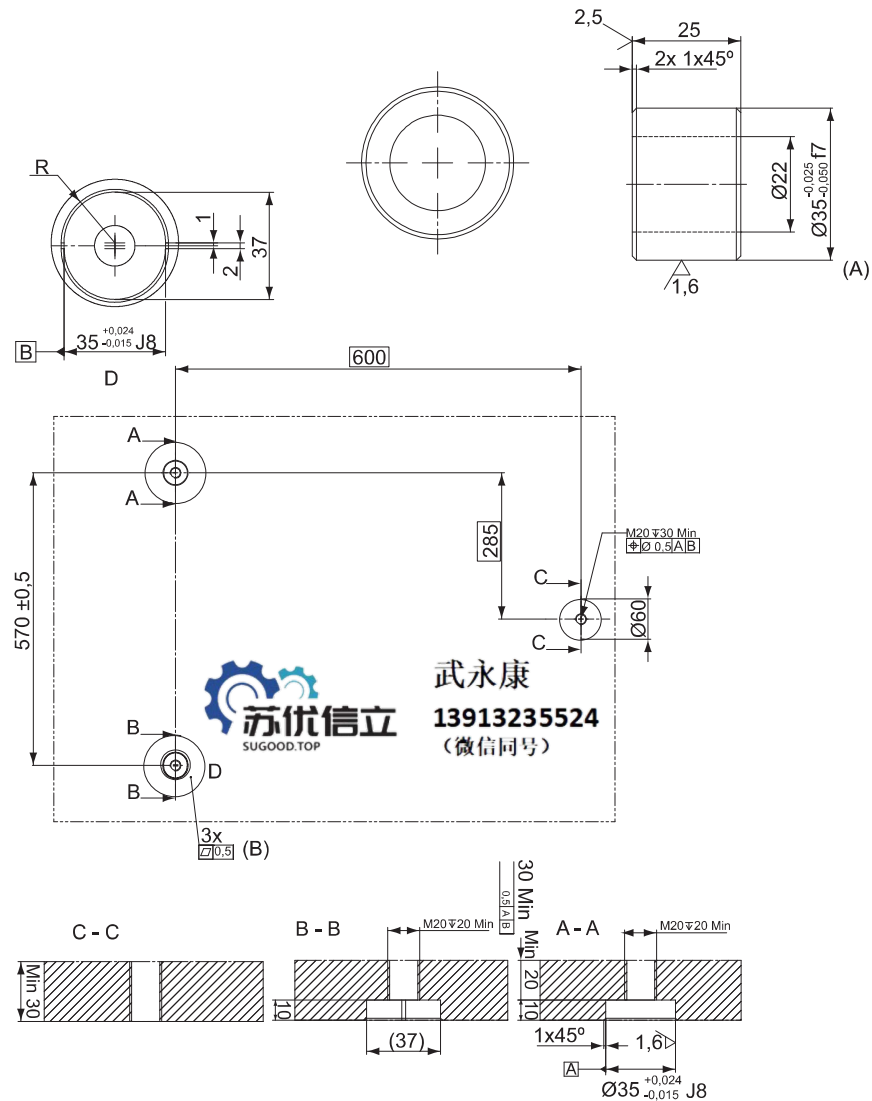

xx110000604

Pos	Description
A	Surface treatment, ISO 2081 Fe/Zn 8 c2 Guide bushings
B	Common zone