

1 Description

1.6 Mounting equipment

Continued



Note

Maximum loads must never be exceeded!

Tool flange

IRB 4400/60

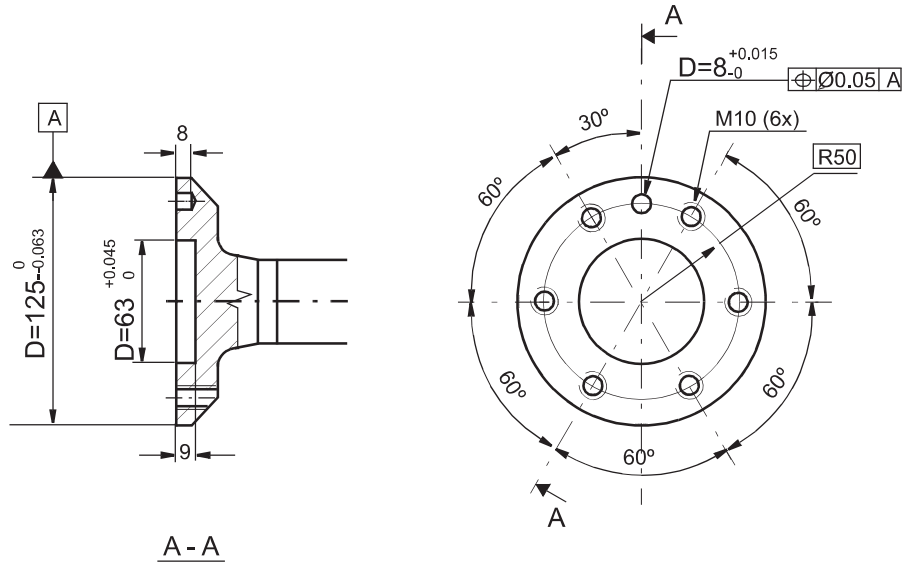

xx1100000602



武永康
13913235524
(微信同号)

IRB 4400/L10

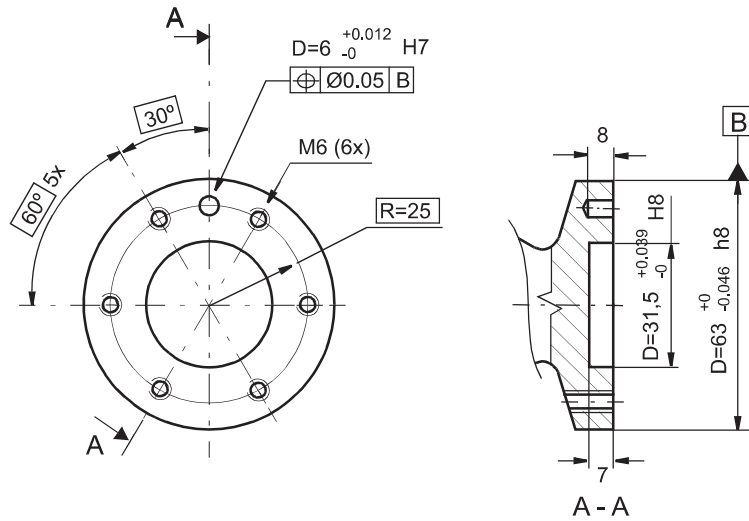

xx1300002626

For fastening of gripper tool flange to Robot tool flange every one of the screw holes for 6 screws, quality class 12.9 shall be used. Min. 10 mm used thread length.