

1 Description

1.3.3 Mounting the manipulator

Continued

Fastening holes on the robot base

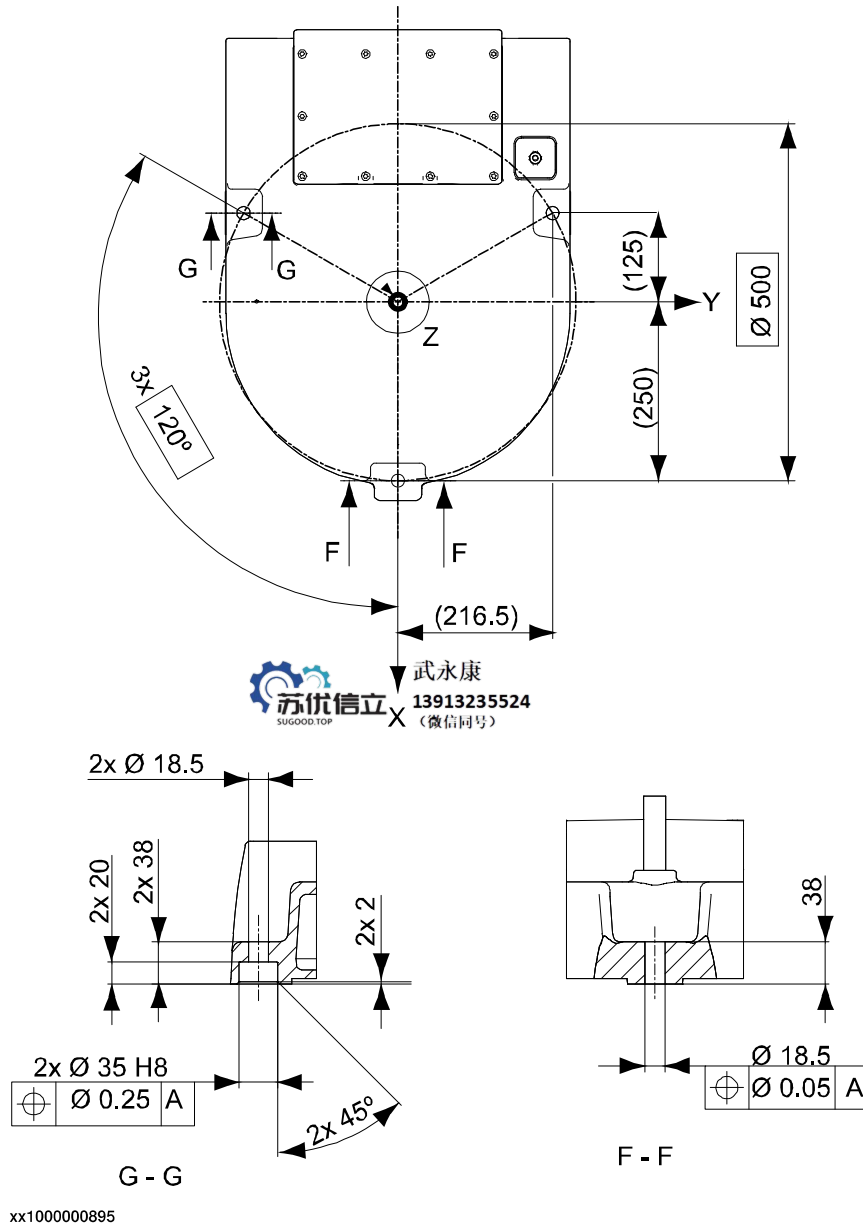

Attachment bolts, specification

The table below specifies required bolts and washers for securing the robot at installation site.

Specification	Description
Attachment bolts, 3 pcs	M16 x 60 (installation directly on foundation) M16 x 70/80 (installation on foundation or base plate, using guiding sleeves)
Washers, 3 pcs	17 x 30 x 3
Quality	Quality 8.8, wall mounted quality 12.9
Tightening torque	200 Nm

Continues on next page



Note

For wall mounted robots, two guide bushings according to the following figure are needed.



Note

Regarding Abs.Acc. performance, the chosen guide holes according to Figure in the beginning of this chapter are recommended.

Mounting surface and bushings

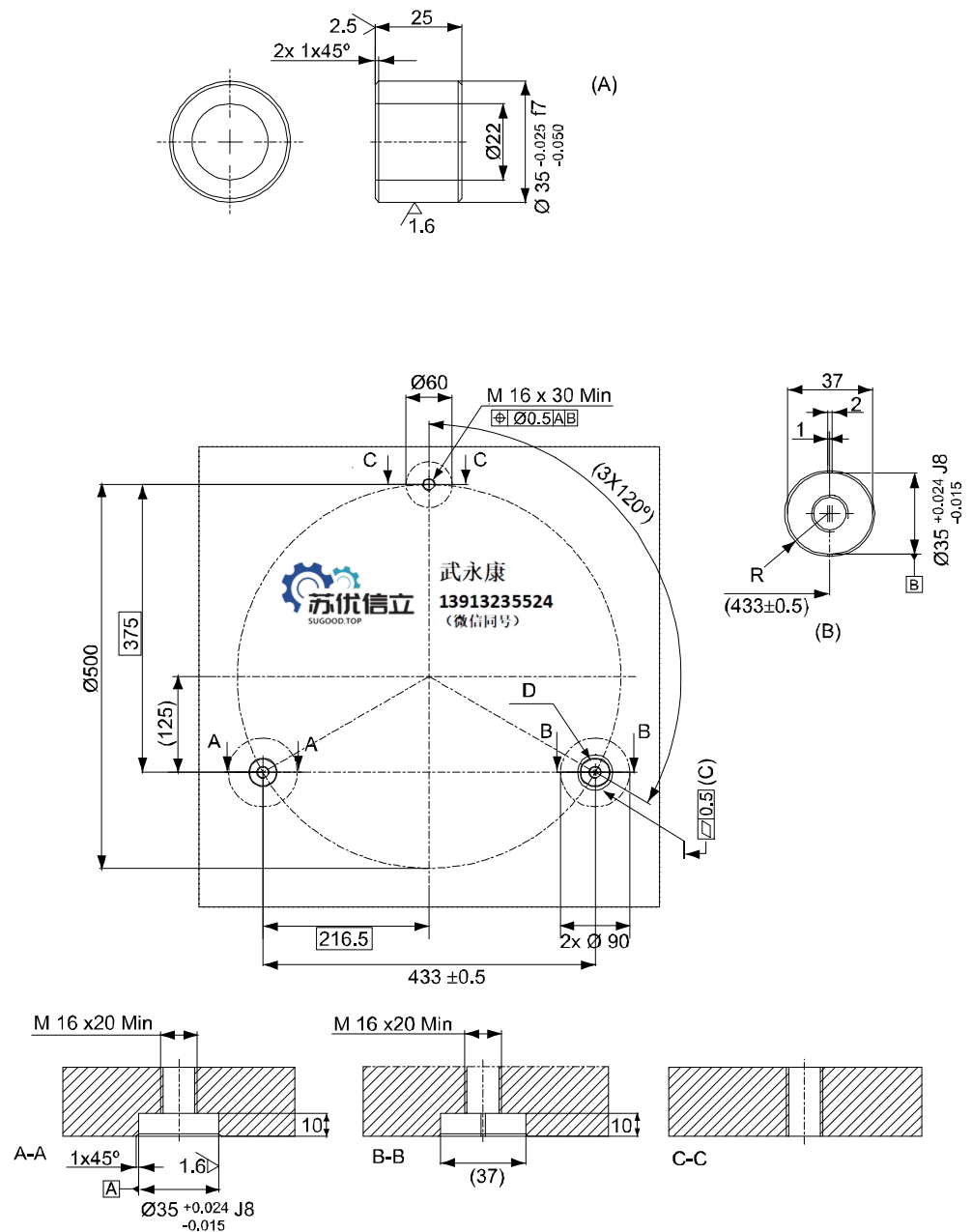

xx100000896

Continues on next page