

Tool flange IRB 2600

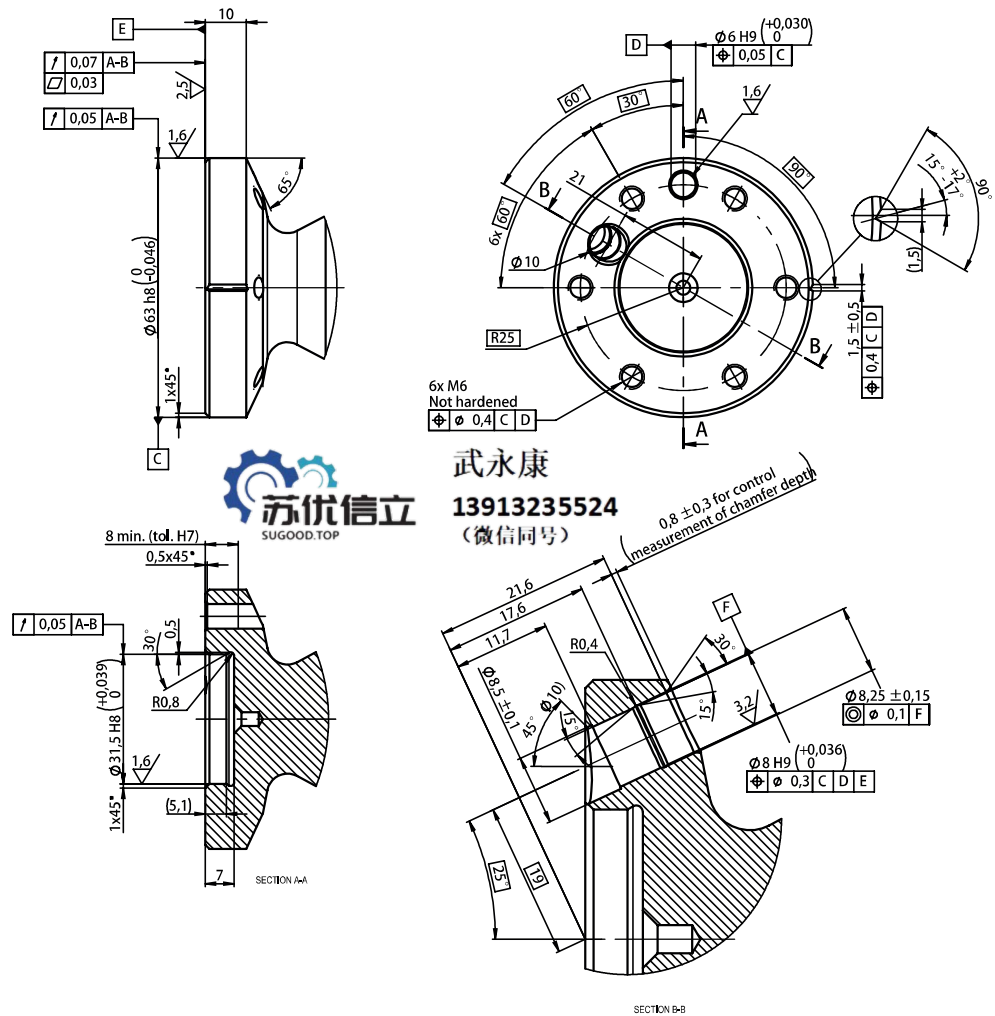

xx0800000449

For fastening of gripper tool flange to Robot tool flange every one of the screw holes for 6 screws, quality class 12.9 shall be used. Min. 10 mm used thread length.

1 Description

1.6.1 Information about mounting equipment

Continued

Tool flange/wrist for IRB 2600ID

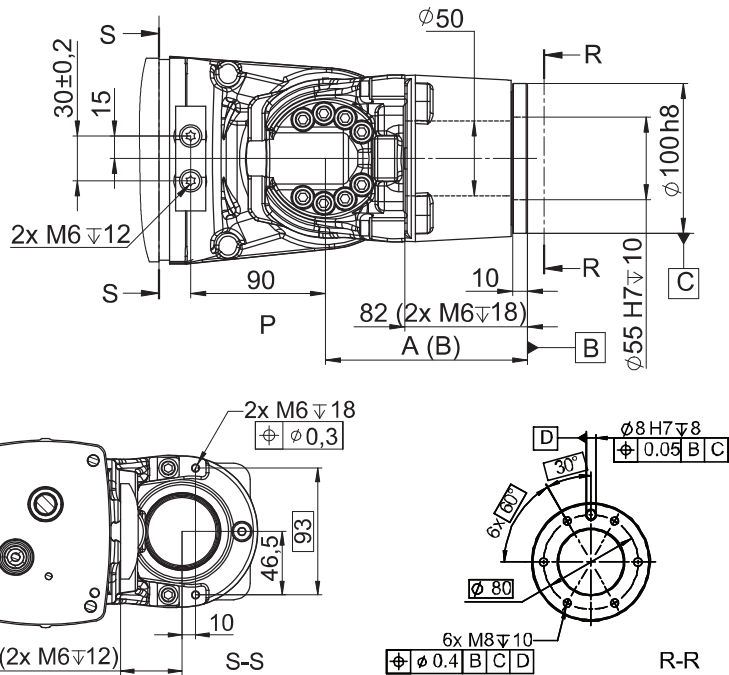
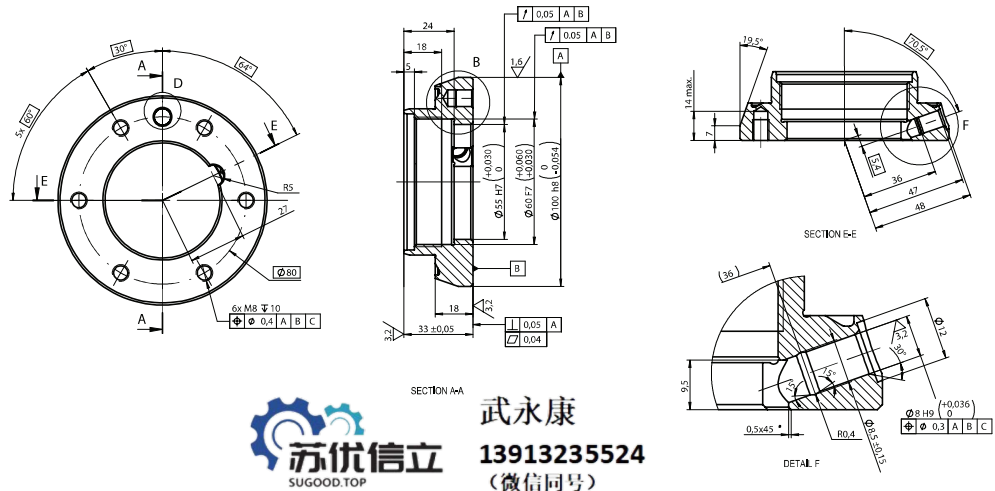

xx1000000969

| Pos | Description |
|-----|-------------------------------|
| A | 135 mm for IRB 2600ID-15/1.85 |
| B | 200 mm for IRB 2600ID-8/2.00 |

For fastening of gripper tool flange to Robot tool flange every other one of the screw holes for 6 screws, quality class 12.9 shall be used.